

Thermador[®]
C O R P O R A T I O N

Cooktop
Models TMH/ST/
TMHCV
Care and Use Manual

A Special Message to Our Customers,

We are glad you selected this Thermador Cooktop. We recommend that you take time to read this entire booklet before using your new appliance for the first time.

A good ventilation system, whether at the back of the cooktop (Cook'n'Vent model) or an overhead hood, is as important to your cooking satisfaction as is your cooktop. It will remove cooking odors and smoke from the cooking area and help to maintain cleaner walls and furnishings in your home.

The booklet contains suggestions we believe will be helpful as well as directions for using all the features of this cooktop. Keep it in a handy place, as it has the answers to questions that may occur when you start to cook.

Let us know if we can help you. When you write, please include the model and serial numbers of your cooktop.

Sincerely,

The Home Economics Staff

TABLE OF CONTENTS

Section One: General Safety Instructions	
Safety Practices.....	2
Section Two: Before you Begin	
Before Using Your Cooktop.....	3
Section Three: Description	
Model and Parts Identification.....	4
Section Four: Using the Cooktop	
Cooktop Operation.....	6
Proper Cookware.....	8
Heat Setting Chart.....	10
Section Five: Using the Griddle'n Grill	
Griddle'n Grill Operation.....	12
Section Six: Care and Maintenance	
Cleaning Chart.....	14
Cook'n'Vent Care.....	16
Section Seven: Service	
Before Calling for Service.....	18
Warranty.....	19

Your safety is important to us.

This manual contains safety symbols and statements. Please pay attention to these symbols and follow any instructions. Here is a brief explanation of the use of these symbols.

 **WARNING**

This symbol will help alert you to such dangers as personal injury, burns, fire and electrical shock.

 **CAUTION**

This symbol will help you avoid actions which could cause product damage (scratches, dents, etc.) and damage to your personal property.

PRECAUTIONS

SAFETY PRACTICES TO AVOID PERSONAL INJURY

IMPORTANT SAFETY INSTRUCTIONS

WARNING - TO REDUCE THE RISK OF FIRE, ELECTRIC SHOCK, OR INJURY TO PERSONS, OBSERVE THE FOLLOWING:

- A. Use this unit only in the manner intended by the manufacturer. If you have any questions, contact the manufacturer.
- B. Before servicing or cleaning unit, switch power off at service panel and lock service panel to prevent power from being switched on accidentally.

CAUTION: For General Ventilating Use Only. Do Not Use To Exhaust Hazardous or Explosive Materials and Vapors.

WARNING - TO REDUCE THE RISK OF A RANGE TOP GREASE FIRE:

- A. Keep fan, filters and grease laden surfaces clean.

- B. Always turn hood ON when cooking at high heat.
- C. Use high range settings on range only when necessary. Heat oil slowly on low to medium setting.
- D. Do not leave range unattended when cooking.
- E. Always use cookware and utensils appropriate for the type and amount of food being prepared.

WARNING - TO REDUCE THE RISK OF INJURY TO PERSONS, IN THE EVENT OF A RANGE TOP GREASE FIRE, OBSERVE THE FOLLOWING:

- A. SMOTHER FLAMES with a close-fitting lid, cookie sheet, or other metal tray, then turn off the gas burner or the electric element. BE CAREFUL TO PREVENT BURNS. If the flames do not go out immediately

EVACUATE AND CALL THE FIRE DEPARTMENT.

- B. NEVER PICK UP A FLAMING PAN - You may be burned.
- C. DO NOT USE WATER, including wet dishcloths or towels - a violent steam explosion will result.
- D. Use an extinguisher **ONLY** if:
 1. You know you have a Class ABC extinguisher, and you already know how to operate it.
 2. The fire is small and contained in the area where it started.
 3. The fire department is being called.
 4. You can fight the fire with your back to an exit.

When properly cared for, your new Thermador Cooktop has been designed to be a safe, reliable appliance. When using kitchen appliances, basic safety precautions must be followed, including the following:

Read this Care and Use Manual carefully before using your new cooktop to reduce the risk of fire, electric shock, or injury to persons.

Begin by insuring proper installation and servicing. Follow the installation instructions provided with this product. Have the cooktop

installed and grounded by a qualified technician.

Do not repair or replace any part of the appliance unless specifically recommended in this manual. All other servicing should be referred to a qualified technician.

Children should not be left alone or unattended in an area where appliances are in use. They should never be allowed to sit or stand on any part of the appliance.

CAUTION: Do not store items of interest to children above the

cooktop or at the back of it. If children should climb onto the appliance to reach these items, they could be seriously injured.

Do not store flammable materials on or near the cooktop.

Do not use water on grease fires. Turn appliance off and smother fire with baking soda or use a dry chemical or foam-type extinguisher.

Never let clothing, potholders, or other flammable materials come in contact with any element until it has cooled.

Use only dry potholders: moist or damp potholders on hot surfaces may cause burns from steam. Do not use a towel or other bulky cloth in place of potholders. Do not let potholders touch hot elements.

For personal safety, wear proper apparel. Loose fitting garments or hanging sleeves should never be worn while using this appliance.

Do not use aluminum foil to line any part of the cooktop. Improper use of a foil liner could result in a shock or fire hazard. Foil is an excellent heat insulator and heat will be trapped beneath it. This will upset the cooking performance and can damage the finish of the cooktop drip pans.

Warning: The appliance is for cooking. Based on safety considerations, never use the cooktop to warm or heat a room. Also, such use can damage the cooktop parts.

Do not heat unopened food containers; a buildup of pressure may cause the container to burst.

When using the cooktop: **DO NOT TOUCH ANY HEATING ELEMENTS or THE IMMEDIATE SURROUNDING AREA.**

Even though dark in color, the heating elements may be hot. Areas adjacent to the elements may become hot enough to cause burns.

Never leave the cooktop unattended when using high heat settings. Boilovers cause smoking and greasy spill overs that may ignite.

Only certain types of glass, heat-proof glass-ceramic, ceramic, earthenware, or other glazed utensils are suitable for cooktop use. This type of utensil may break with sudden temperature changes. Use only on low or medium heat settings according to the manufacturer's directions.

To minimize burns, ignition of flammable materials and unintentional spillovers, **position handles of utensils inward** so they do not extend over adjacent work areas, cooking areas, or the edge of the cooktop.

Hold the handle of the pan to prevent movement of the utensil when stirring or turning food.

Clean the cooktop with caution. Avoid steam burns; do not use a wet sponge or cloth to clean the cooktop while it is hot. Some cleaners produce noxious fumes if applied to a hot surface.

DO NOT soak or immerse in water any removable heating elements. Turn the elements on and they will clean themselves. Do not leave the cooktop unattended when burning food soil off the elements.

Clean the hood above the cook-top or the ventilator at the back of your cooktop frequently so grease from cooking vapors does not accumulate on the filters or on the intake.

Turn the ventilator OFF in case of fire or when intentionally "flaming" liquor or other spirits on the cooktop. The blower, if in operation, could unsafely spread the flames.



CAUTION

Make sure drip reflector bowls, secondary drip pans and drip trays are in place before cooking on the cooktop. If not in place, wiring and components under the cooking surface and counter top may be damaged.

This cooktop is equipped with elements of different sizes. **Always use utensils that have flat bottoms and that are large enough to cover the entire element.** The use of a utensil smaller than the size of the element will expose a portion of the element to direct contact with the user which could result in burns.

SAVE THESE INSTRUCTIONS

Section Two: Before You Begin

BEFORE USING YOUR COOKTOP FOR THE FIRST TIME

Remove all packaging materials and labels from cooktop and griddle.

1. Check that you have these items.

- ▲ Griddle'n Grill™ (drip pan, cover, griddle, grill, removable element) - Models TMHCV36G, TMH36/45.
- ▲ Drip Bowls - Models TMH30
- ▲ Drip Tray - Models TMH36G and THMVC36G
- ▲ Installation Instructions
- ▲ Registration Card

2. Read the basic information in this manual.

MODELS and PARTS IDENTIFICATION

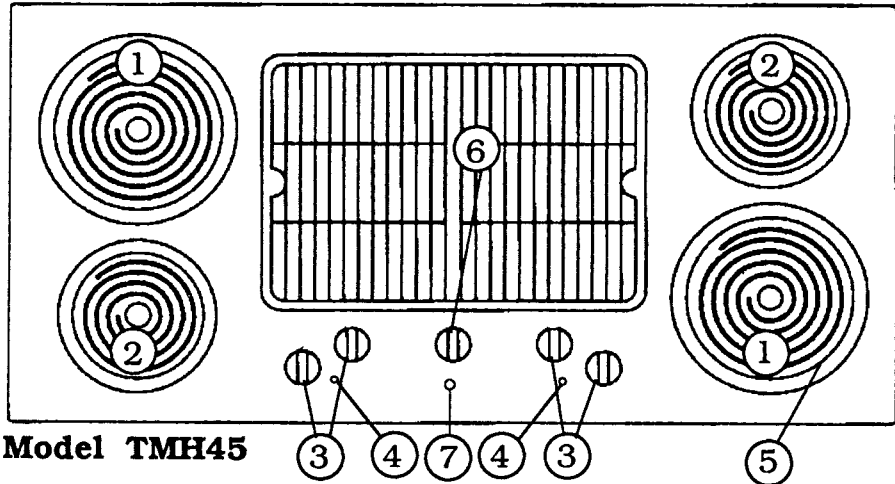

1. 8" Element - 2100 Watts
2. 6" Element - 1500 Watts
3. Surface Element Control Knobs
4. Element ON Lights
5. Reflector Bowls and Drip Pans/Trays (under elements)
6. Griddle'n Grill™* and Control Knob
TMH45 - 1750 Watts
TMH36G - 1400 Watts
7. Griddle'n Grill™* Element ON Light

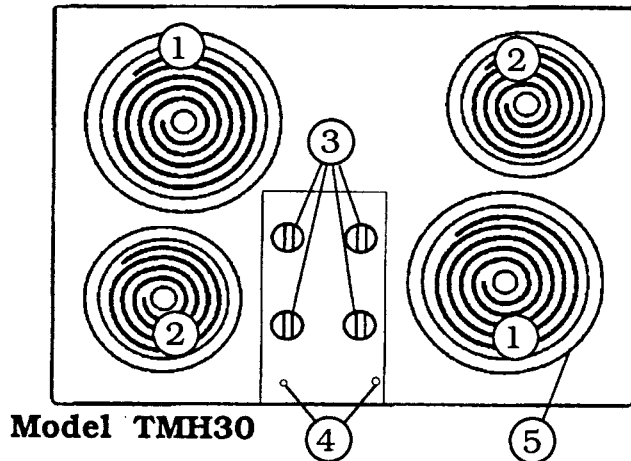
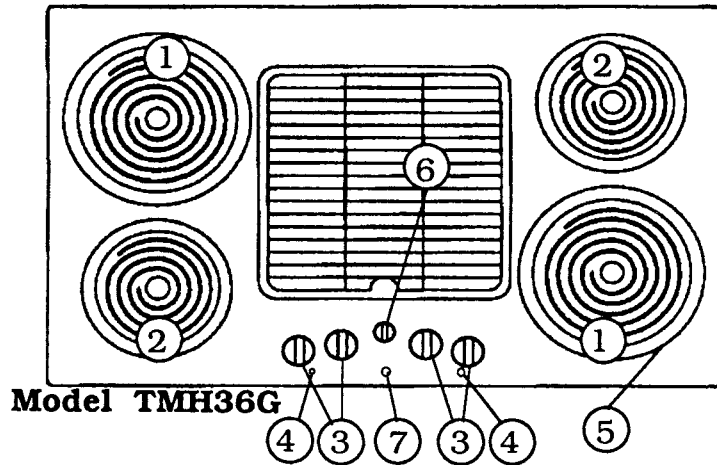

MODELS and PARTS IDENTIFICATION

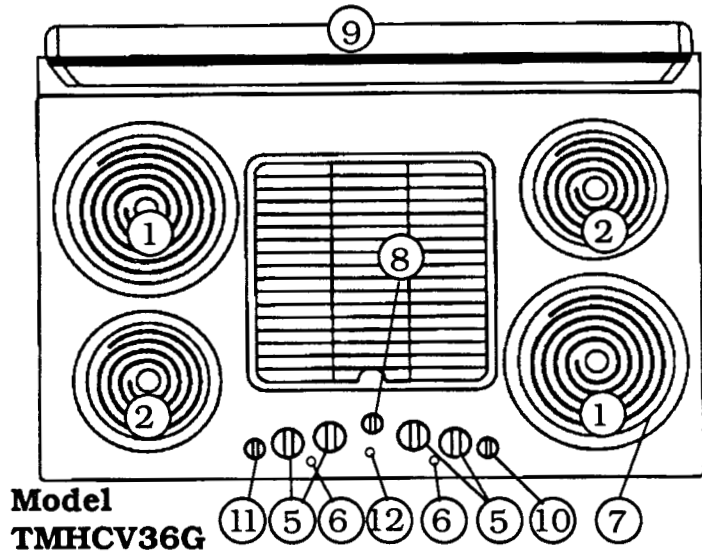

1. 8" Element - 2100 Watts
2. 6" Element - 1500 Watts
3. 6" Element - 1250 Watts
4. 6" Element - 1100 Watts
5. Surface Element Control Knobs
6. Element ON Lights
7. Reflector Bowls & Drip Pans/Trays (under elements)
8. Griddle'n Grill™* and Control Knob
Griddle'n Grill Element - 1400 Watts
9. Cook'n'Vent™ Ventilator*
10. Ventilator UP and DOWN Switch
11. Blower Speed Control
12. Griddle'n Grill Element ON Light

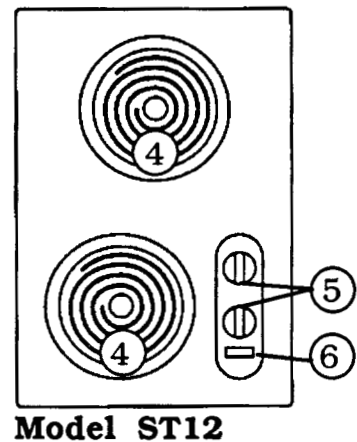
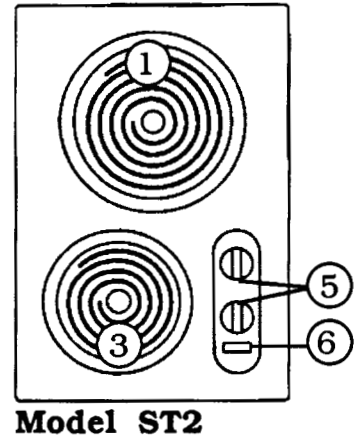

*(not on all models)

COOKTOP OPERATION

The following pages explain how each feature on the cooktop works and how to get the best cooking results.

Follow these hints when cooking on the cooktop.

- ▲ Use proper cookware, see page 8.
- ▲ Center the pan on the element before turning on the element.
- ▲ Use cookware that is large enough to accommodate the amount of food or liquid being heated, to eliminate the possibility of boil overs and spattering. Be sure the utensil fits the element.
- ▲ To cook a particular food, refer to the Heat Setting Chart for suggested heat settings.

RADIANT COIL ELEMENT and GRIDDLE 'n GRILL CONTROLS

These are "Vari-Speed" controls with an infinite number of heat settings. There are no fixed positions between HI and LO; the numbers on the control knob are a guide to various heat settings.

To turn on any of the elements, push down on the appropriate control knob and turn it in either direction to the desired setting.

SIGNAL LIGHTS

TMH MODELS

When any control knob is turned on, an Element ON Light glows red. This light turns on when an element is turned away from OFF, and remains on as long as the element is ON.

ST Models

These models have one light. It is ON as long as a control knob is turned away from OFF.

CAUTION:

- ▲ **Foods packaged in aluminum foil** should *not* be placed directly on an element for cooking; aluminum foil can melt.
- ▲ **Plastic, paper and cloth can melt or burn** when in contact with a hot element. **Do not** let these items come in contact with the elements.
- ▲ **Do not allow pans to boil dry.** This can damage the pan, element, drip pan and/or the cooktop.

SURFACE ELEMENTS

When an element is turned on, you receive a constant amount of heat corresponding to the dial setting. Start most cooking on HI, then reset the dial to the lowest setting needed to finish the cooking. The heat will be on continuously until the switch is turned to OFF.

An empty pan, left on an element that is turned on, can reach temperatures hot enough to damage or even melt the pan.

When a pan is removed from a hot element, you may notice an uneven red and black appearance on the element; this is normal. The darker areas indicate where the pan was pressing tightest against the element. The red and black areas show that the pan being used is warped and energy is being wasted.

Electric surface elements are designed to put heat directly into the bottom of the cooking utensil. The bottom of the pan must be in direct contact with the heating element. Be sure the reflector bowls and drip trays are in place during cooking to insure proper operation of the element.

REFLECTOR BOWL

DO NOT TURN ANY ELEMENT ON WITHOUT REFLECTOR BOWLS IN PLACE.

Be sure to clean soiled reflector bowls before the cooktop is used again. Some food soil, when heated a second time, bakes into the surface and cannot be removed. The use of high heat for an extended period of time may cause the bowls to discolor. This is normal. **CAUTION: Reflector bowls should be replaced if excessive discoloration or corrosion occurs. This condition can result in high component temperatures.**

This cooktop has plug-in elements which make it possible to clean the reflector bowls without having to lift the entire top (the ST Models do not lift up, however you can still remove the reflector bowls).

Models ST

Remove Reflector Bowls and Trim Rings as Follows:

1. Lift element.
2. Remove reflector bowl.

Section Four: Using the Cooktop

COOKTOP OPERATION

3. Slip the element down through the trim ring and lay it inside the cooktop.
4. Snap off the trim ring.

Models TMH

Remove One Piece Reflector Bowls as Follows:

1. Pull element support prong from slot in the reflector bowl.
2. Remove element by pulling from the receptacle.
3. Lift reflector bowl from top.

Replace One Piece Reflector Bowls as Follows:

1. Align cut-out in reflector bowl with receptacle and set in top.
2. Insert the element terminals into the receptacle.
3. Insert element support prong into the slot in the reflector bowl and press element down firmly.

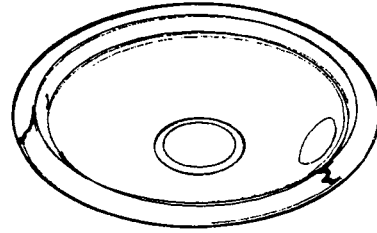

TO LIFT THE COOKTOP (Models TMH only)

Remove the two front elements and reflector bowls, then lift in the element area.

DO NOT LIFT BY THE ELEMENTS

As the cooktop is raised the support stand should drop towards the front of the rough-in box. With one hand, firmly hold the cooktop in the raised position. Use the other hand to pull the support stand forward to the front of the rough-in box. This holds the support stand in the raised position. Make certain support stand is secure before reaching under the cooktop. The porcelain enamel rough-in box is now ready to clean.

Model TMH36G Shown
REMOVE ELEMENTS AND LIFT HERE

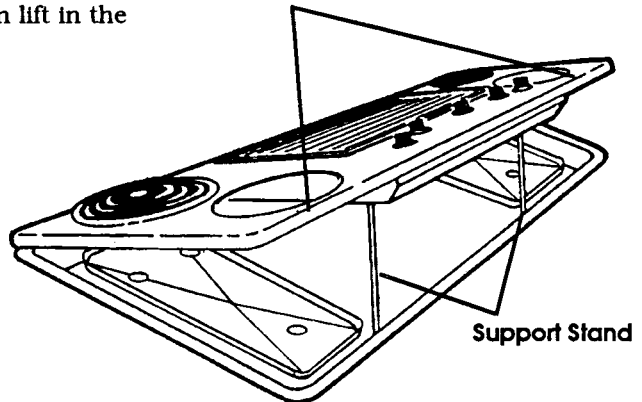

TO LOWER THE COOKTOP

Hold the cooktop with one hand and push on side of the support stand towards the rear of the rough-in box. **When the support stand is released, use two hands to lower the cooktop** to the counter level.

Pull Support Stand Fully Forward and Secure Firmly

SECONDARY DRIP TRAY/PAN

CAUTION: Burner secondary pans/trays must be in place while operating cooktop.

If not in place, wiring and components under the cooking surface may be damaged.

The anodized aluminum drip pans on 30 inch models, and stainless steel drip trays on 36 inch models are positioned under the reflector bowls. The pans /trays can be removed for cleaning by raising the main top.

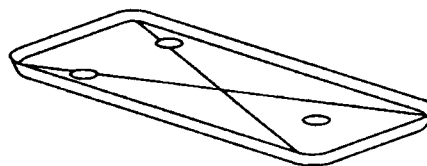

Secondary Drip Tray 36 inch Models

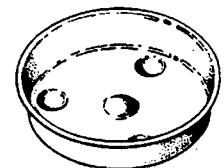

Secondary Drip Pan 30 inch Models

CONTROL KNOBS

The control knobs are arranged so they can be readily associated with the element they control. To turn the element ON push down and turn in either direction.

PROPER COOKWARE

Top performance of your new Thermador Cooktop requires the use of proper pots and pans. An out-of-shape pan without a lid, cannot possibly cook with the same speed and evenness as a pan with a heavy, flat bottom and a good fitting lid.

Cookware should have the following characteristics:

- Good heat conductivity
- Bottom diameter matching the size of the element or flame used
- Good balance (pan bottom remains level on element/burner grate)
- Flat, heavy bottom that does not warp when hot; provides even heat
- Proper fitting lid (when needed for specific cooking methods)

Do not use cookware with these characteristics:

- Thin bottom
- Concave bottom (when heated)
- Convex bottom (when heated)
- Poor balance (rocks back from weight of handle)

Many different types of pans can be used on this cooktop. To get the best cooking results:

Use cookware that has good heat conductive qualities. Metal cookware that has copper or aluminum imbedded in a stainless steel disk bottom ("tri-ply construction") conducts heat better than other metal cookware.

Use flat, heavy bottom pans that stay flat when heated. Avoid cookware that is warped, dented,

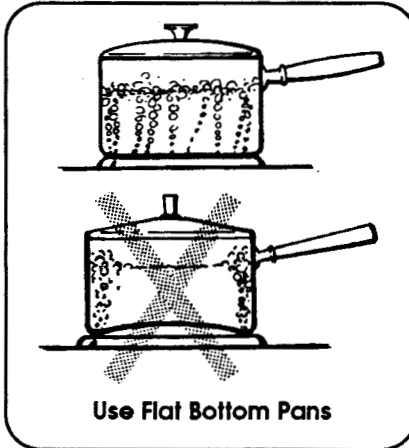

Use Flat Bottom Pans

ridged, or thin. A warped or ridged pan receives the most heat at the point/s that contact the element/flame. This can result in burning or scorching of the food being prepared.

Use medium to heavy gauge pans. These pans resist warping and last longer than thin pans. The weight or thickness of the pan material (gauge) should be heavy enough to conduct heat evenly over the bottom of the pan for even browning and to avoid scorching.

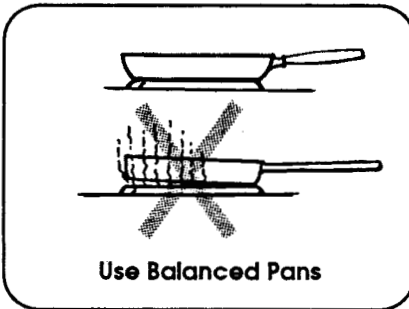

Use Balanced Pans

Use balanced pans that sit level on the element without rocking.



Use a good fitting Lid

Use lids that fit the cookware properly to help shorten the cooking time and to allow food to

cook in a minimum amount of liquid on a lower heat setting.

Heat and cool pans gradually to help maintain a flat bottom on your cookware. Do not place pans under cold water while still hot, unless recommended by the manufacturer as they may warp.

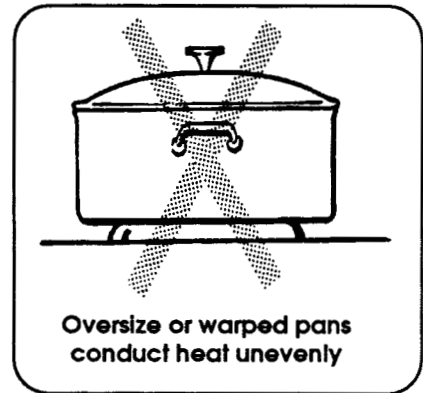

Oversize or warped pans conduct heat unevenly

Do not use unusually large or warped utensils such as canners and stock pots on HI heat for an extended period of time. This may cause heat build up which can result in damage to the cooktop or the surrounding countertop. Once food has reached temperature, turn the control setting down to maintain the cooking heat.



Unsuitable Specialty Pan

Specialty pans such as woks, lobster pots, pressure cookers, griddles, French fryers, etc. must meet similar design requirements as regular cookware: flat bottom, balanced, correct size, and proper cover (if applicable).

Do not use utensils such as griddles, roasting pans, au gratin pans, fish poachers or other cooking utensils that must fit

PROPER COOKWARE

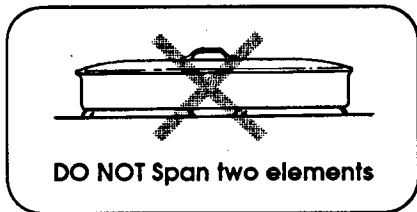

DO NOT Span two elements

across two elements/burners. Use of these products can result in damage to the enamel cooktop.

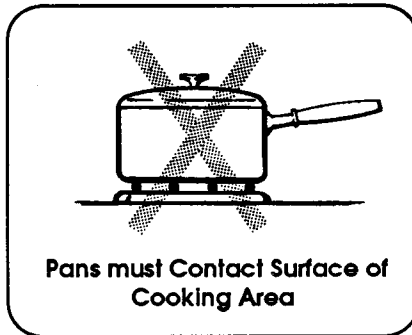

Pans must Contact Surface of Cooking Area

properly. **Do not use a wire trivet** or other heat retarding pad.

Canning Tips:

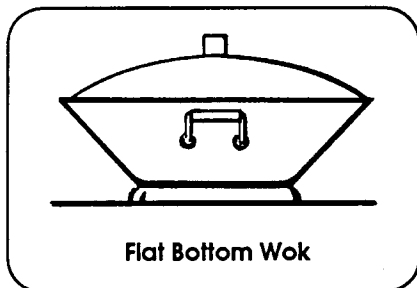

Flat Bottom Wok

Use only a flat bottomed wok on an electric cooktop.

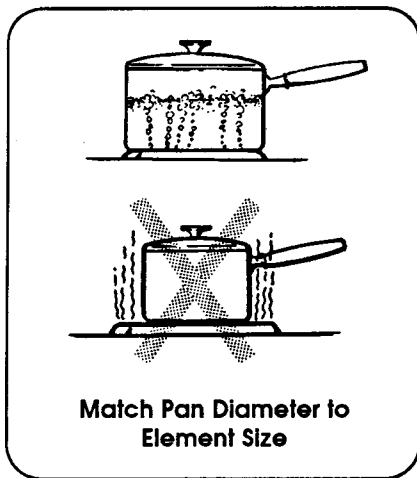

Match Pan Diameter to Element Size

Match the bottom diameter of the pan to the element. The pan should be the same size as the element or slightly larger (up to 1-inch overhang). Avoid using utensils that are smaller in diameter than the element. Smaller utensils result in energy loss and increase the potential for burns. If the diameter of the pan is too large (over 1-inch larger than the element), the cooking time will be increased.

Utensils must be in direct contact with the element to cook

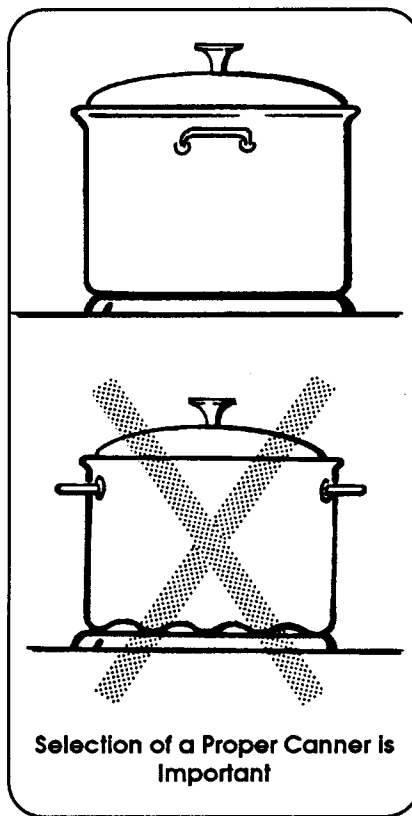

Selection of a Proper Canner is Important

- Select a canner whose bottom diameter, in direct contact with the element, is as close to the element size as possible but extends no more than 2 inches beyond the element.
- Use the lowest heat setting possible to maintain a boil or pressure.
- Be sure to cover all containers.
- Follow the canning instructions given in a standard cookbook or manufacturers' instructions provided with the canner or the jars.
- Use care to prevent burns from the large amount of steam generated by the canning process.

Look for canners fitting this description:

- ▲ **Water Bath Canner:** Standard 21 to 22-quart canners with an 11 to 12-inch diameter and a 9 to 11-inch depth.
- ▲ **Pressure Canner:** Canners vary in size from 8 to 22-quarts with 8 to 11-inch bottom diameters and a 6-1/2 to 12-inch depth.

- Be sure reflector bowls are clean and in good condition. Make sure secondary drip pan/trays are in place. The high continued temperatures from canning can damage the countertop if the bowls are not in good condition.
- Select a canner with a flat bottom, rather than one with a concave, convex or rippled bottom.

HEAT SETTING CHART GUIDELINES

The following Heat Setting Chart is to be used as a **guide**. Your pans or your manner of cooking may need a different setting than what is suggested. All heat settings were determined using a variety of good quality, flat bottom pans with lids (unless the method of cooking did not require a covered pan). Pans were matched to the size of of the electric element or extended no more than 1-inch beyond it.

How to Use the Chart

The chart is divided into two sections: the food, the element heat settings. It shows an initial (Start Cooking) setting and a suggested point at which you may want to turn the heat to a second (Continue Cooking) setting. Sometimes there is no change in the heat setting. Example: to cook

fresh vegetables, bring water and vegetables to a boil on the HI setting. Once the water is boiling, lower the heat setting to suggested setting to finish cooking the vegetables to the desired doneness.

GUIDELINES

1. **The actual heat setting used to cook is selected from the range of heat settings given.** Whether the higher or lower setting is selected depends on the quality of the pan, the amount of food, and the wattage of the element used.
2. **Use the retained heat** in the cookware and the element to finish the cooking. Turn off the element when the food is almost finished cooking. This retained heat can also be used to hold foods at serving temperatures for a short while.
3. **Raise or lower the heat setting gradually.** Allow time for the element and pan to adjust to the new setting. Changes are more satisfactory when the increased or decreased setting is only one or two markings on the control knob.
4. **When a setting is raised,** the change in heat will be noticed sooner than when a setting is lowered.
5. **When the heat setting is too high,** it takes longer to notice the effect of a reduced setting because of the retained heat in the pan and element.

SUGGESTED HEAT SETTINGS CHART

Food	Start Cooking	Continue Cooking	Food	Start Cooking	Continue Cooking
BEVERAGES Cocoa	5 to 6 — heat milk, cover	LO to 2 — finish heating	DESSERTS Pudding and Pie Filling	5 to 6 — cook according to package directions	5 to 6
BREADS French Toast, Pancakes, Grilled Sandwiches	HI — preheat skillet	4 to 5 — cook	EGGS Cooked in Shell	HI — cover, bring water to a boil, add eggs, cover	OFF to 2 — cook 3 to 4 minutes for soft cooked; or 15 to 20 minutes for hard cooked
BUTTER	LO to 2 — allow about 5 to 10 minutes to melt	LO to 2	Fried, Scrambled	HI — melt butter, add eggs	LO to 2 — finish cooking
CEREALS Cornmeal, Grits, Oatmeal	HI — cover, bring water to a boil, add cereal	LO to 3 — finish cooking according to package directions	Poached	HI — bring water to the steaming point, add eggs	LO to 2 — finish cooking
CHOCOLATE	LO to 2 — allow about 10 to 15 minutes to melt	LO to 2	MEAT, FISH, POULTRY Bacon, Sausage Patties	HI — until meat starts to sizzle	2 to 3 — finish cooking
DESSERTS Candy	5 to 7 — cook following recipe	5 to 7			

SUGGESTED HEAT SETTINGS CHART

Food	Start Cooking	Continue Cooking	Food	Start Cooking	Continue Cooking
MEAT, FISH, POULTRY Braising: Swiss Steak, Pot Roast	HI — melt fat, then brown on 4 to 5, add liquid	LO to 2 — cover, simmer until tender	Pressure Cooker Vegetables	HI — build up pressure	4 to 5 — to maintain pressure
Quick Frying: Breakfast Steaks	9 to HI — preheat skillet	9 to HI — fry quickly	RICE	HI — cover, bring water to a boil, add rice	LO to 2 — cover, cook according to package directions
Frying: Chicken	HI — heat oil, then brown on 4 to 5	2 to 4 — cover, finish cooking	SAUCES Tomato Base	9 to HI — cook meat/vegetables, follow recipe	LO to 3 — simmer
Deep Frying: Shrimp	HI — heat oil	8 to 9 — to maintain temperature	White	7 to 8 — melt fat, follow recipe	3 to 5 — simmer
Pan Frying: Lamb Chops, Thin Steaks, Hamburgers, Link Sausage	HI — preheat skillet	6 to 7 — brown meat and finish cooking	SOUPS, STEWS	HI — cover, bring liquid to a boil	LO to 2 — simmer
Simmering: Stewed Chicken, Corned Beef, Tongue, etc.	HI — cover, bring liquid to boiling	LO to 2 — simmer slowly	VEGETABLES Fresh	HI — cover, bring water and vegetables to a boil,	2 to 3 — cook 10 to 30 minutes, or until tender
PASTAS Macaroni, Noodles, Spaghetti	HI — cover, bring water to a boil, add pasta	7 to 8 — to maintain a rolling boil	Frozen	HI — cover, bring water and vegetables to a boil,	2 to 3 — cook according to package directions
POPCORN (use a heavy, flat bottom pan)	HI — cover, heat until kernels start to pop	3 to 4 — finish popping	Deep Frying	HI — heat oil,	8 to 9 — maintain frying temperature
Pressure Cooker Meat	HI — build up pressure	5 to 6 — maintain pressure	In Pouch	HI — cover, bring water and vegetables to a boil,	LO to 2 — cook according to package directions
			Saute	HI — heat oil or melt butter; add vegetables	5 to 6 — cook to desired doneness
			Stir Fry	HI — heat oil, add vegetables	8 to HI — finish cooking

GRIDDLE 'N GRILL OPERATION

GRIDDLE'n GRILL™

Your new Thermador Griddle'n Grill is a dual purpose appliance; a griddle and a grill. The griddle and the grill are used separately and must sit directly on the element for best cooking results. If the griddle or the grill does not sit on the element, it will not heat enough for foods to cook properly.

The Griddle'n Grill control has an infinite number of heat settings. There are no fixed positions between HI and LO.

To turn the element ON, push down on the control knob and turn it in either direction to the desired setting. See below for the **griddle settings**.

When ON, this element cycles a percentage of HI power on and off to maintain the selected heat setting. On HI it does not cycle.

Griddle Finish

The aluminum griddle is very durable. It features a hard surface that is an integral part of the metal; it is not a coating. This hardness is achieved through a special anodizing process which changes the surface metal structure. This surface will not rust, chip or peel. Because of its hardness, metal utensils may be used on it while cooking; however, cutting food with a knife or other sharp utensil should be avoided.

Stains, Shadows

Stains on the finish usually result from improper cleaning of the griddle. Minor stains, shadows or images are considered normal and do not effect the performance of the griddle. To maintain good performance and appearance, always follow the cleaning instructions, see page 14.

Using the Griddle

As with other anodized kitchen cookware the surface is stick

BEFORE USING THE GRIDDLE or THE GRILL

Wash the griddle and the grill with hot sudsy water, then rinse thoroughly with clear hot water and dry. This should remove any manufacturing oils which may still be on the surface.

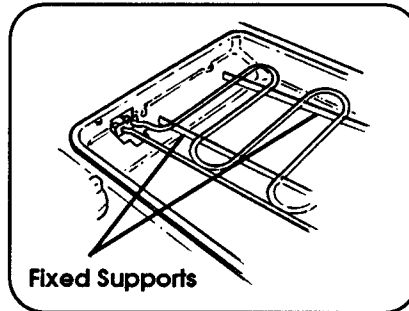

resistant; however a light coating of oil on a preheated griddle will prevent food from sticking during cooking. Preheating for most foods and cooking on the lower heat settings help prevent sticking. Remember, many meats (bacon, sausage, etc.) are best started on a cold griddle. To cook eggs after cooking bacon or sausage, allow griddle to cool slightly, scrape the griddle well with a metal spatula, add a little grease to the griddle, then add the eggs. Some butter or oil must be used to cook eggs or they will stick.

1. Remove the Griddle'n Grill cover and be sure the element is plugged all the way into the receptacle. The two fixed supports on the bottom of the element must rest in the indentations in the bottom of the drip pan.

2. Place the griddle directly on top of the element.
3. **Preheat the griddle according to the chart.**
4. Place food on the griddle.
5. Adjust the heat setting for the food being cooked.

Griddle settings may need to be adjusted to a lower setting if the griddle is used for an extended

SUGGESTED HEAT SETTINGS CHART - GRIDDLE

Food	Preheat At Setting	Cook at Setting
BREADS French Toast, Pan cakes, Grilled Sandwiches	HI to 8 — to preheat , about 10 minutes	7 to 8 — to cook
EGGS Fried, Scrambled	5 to 6 — to preheat, about 5 minutes, then melt butter, add eggs	3 to 4 — to cook
FISH Fish Sticks	HI — to preheat	7 to 9 — to cook
MEAT Bacon, Sausage Patties, Ham Slice	Do not preheat. HI — until meat starts to sizzle, about 3 to 4 minutes	6 to 8 — to cook.
Hamburgers, Sausage Links	HI — until meat starts to sizzle	8 to HI — to cook.
Vegetables Hash Brown Potatoes	HI — to brown	8 to HI — to cook.

The Grill

DO NOT leave the grill unattended while grilling food.

1. Remove the Griddle'n Grill cover. Be sure the element is plugged all the way into the receptacle. The two fixed supports on the bottom of the element must rest in the indentations in the bottom of the drip pan.

DO NOT USE BRIQUETS OR COALS OF ANY KIND UNDER THE GRILL

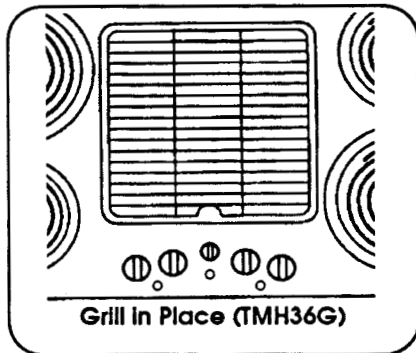

2. Place the grill directly on top of the element.
3. Turn the control knob to HI and preheat the grill for 10 minutes.

NOTE: The hot grill will sear the food, sealing in the juices. The longer the preheat, the faster the meat browns and the darker the grill marks.

4. Place the food on the grill and cook to desired doneness.
5. Most foods are cooked at the HI heat setting for the entire cooking time.

Grilling Hints

Foods cooked for a long time or basted with a sugary marinade may need a lower heat setting near the end of the cooking time. The control knob may be set at any indicated setting or to any position in between.

If large amounts of meat are cooked at one time, occasionally there will be grease drippings that ignite and create minor puffs of flame for a brief second or two. This is a normal part of the cooking process. **Should flame become excessive, remove the food from the grill; turn the control to OFF. Use baking soda to extinguish the flames.**

NOTE: Quantities of accumulated grease may flame or flare up suddenly.

The doneness of meat, whether rare, medium, or well done, is affected to a large degree by the thickness of the cut. Expert chefs say it is impossible to have a rare doneness with a thin cut of meat.

The cooking time is affected by: the kind of meat, the size and shape of the cut, the temperature of the meat when cooking begins, and the degree of doneness desired.

Use a spatula instead of tongs or a fork to turn the meat, as a spatula will not puncture the meat and let the juices run out.

To get the juiciest meats: add seasoning or salt after the cooking is finished; turn the meat only once (juices are lost when the meat is turned several times); and turn the meat just after the juices begin to bubble to the surface.

Trim any excess fat from the meat before cooking. To prevent steaks or chops from curling during cooking, slit the fat around the edges at 1 to 1-1/2 - inch intervals.

To test for doneness, make a small slash in the center of the meat, not at the edge. This will prevent loss of juices.

COOKTOP CLEANING CHART

When cleaning this cooktop:

1. Use the mildest cleaning procedure that will do the job efficiently and effectively. Some cleaners of the same type are harsher than others. Try a small area first.
2. Always rub metal finishes in the direction of the polish lines for maximum effectiveness and to avoid marring the surface.
3. Use only clean soft cloths, sponges, paper towels, fibrous brushes, plastic, non-metal or steel wool soap pads for cleaning and scouring, as recommended on the chart.
4. Any part of this appliance, **except electric elements**, can be cleaned with hot sudsy water. When rinsing is required, rinse thoroughly.
5. Always wipe dry to avoid water marks.

Brand Names

The use of brand names is intended only to indicate a type of cleaner. This does not constitute an endorsement. The omission of any brand name cleaner does not imply its adequacy or inadequacy. Many products are regional in distribution and can be found in the supermarkets.

It is imperative that all products be used in strict accordance with instructions on the package.

The following chart gives directions for cleaning this appliance.

DO NOT CLEAN ANY REMOVABLE PARTS OF THIS APPLIANCE IN ANY SELF-CLEANING OVEN.

Part/Material/Soil	Cleaning Products/Direction
ALUMINUM Filters (TMHCV36G) Secondary Drip Pans (TMH30) • Grease, dirt	Hot sudsy water or wash in dishwasher • Agitate or wash in hot soapy water, rinse thoroughly and allow to dry, or put through a dishwasher cycle.
Griddle, Anodized • Normal Soil	Hot sudsy water. Do not immerse hot griddle in water , allow to cool, then cover with wet paper towels. • Wash, rinse thoroughly with hot water, and dry. To maintain the attractive appearance of the griddle and to keep its cooking efficiency, <u>it is important that the griddle be thoroughly cleaned after each use.</u> Always completely wash and rinse the griddle using sufficient cleanser and pressure to remove the food soil. If a thin film of food residue is allowed to build up and carbonize when reheated, food may stick. Imprints in areas where food was cooked may be noticed on the slick surface, but this does not effect cooking performance. A very, very light coating of oil rubbed in with a paper towel will even this appearance. In cleaning, use the mildest cleaner and scouring pad necessary to remove the food soil.
• Hard to Remove Soil	Cleansers: Baking Soda, Bon Ami®, Comet®, Ajax® or Zud®. • Use a damp sponge, nylon scrubber. Nylon Scouring Pad: Scotch Brite®. • Use with a powdered chlorine based cleanser such as Comet or Ajax. For stubborn stains make a paste of one of the chlorine based cleaning agents. Allow it to stand for 10 minutes. <u>DO NOT LET THE PASTE OF CLEANSER AND WATER GET DRY. KEEP IT MOIST DURING THE STANDING TIME.</u> Using a circular motion, rub the stain with a nylon pad, wash, rinse thoroughly and dry. <div style="border: 1px solid black; border-radius: 15px; padding: 10px; text-align: center;"> Never wash the griddle in the dishwasher. The caustic detergent used in the dishwasher will discolor the surface. Never use oven cleaners or other harsh cleaning agents, this could destroy the surface. </div>

COOKTOP CLEANING CHART

Part/Material/Soil	Cleaning Products/Direction
Grill <ul style="list-style-type: none"> • Normal Soil <hr/> <ul style="list-style-type: none"> • Heavy Soil 	<p style="text-align: center;">DO NOT USE OVEN CLEANERS</p> <p>Hot sudsy water</p> <ul style="list-style-type: none"> • Always wash and rinse the grill thoroughly after each use. It can be washed in the dishwasher if burned on residue is removed first. <hr/> <ul style="list-style-type: none"> • Soak grill in hot, sudsy water to which a household cleaner like ammonia has been added.
CHROME PLATED Reflector Bowls	<p>Hot sudsy water.</p> <ul style="list-style-type: none"> • Wash, rinse thoroughly with hot water, and dry. <p>Chrome Cleaners: Soft Scrub®, Zud, S.O.S®, Brillo®</p> <ul style="list-style-type: none"> • Never use a non-soap filled steel wool pad, a metal scouring pad or an abrasive scouring powder. These may scratch the finish.
GALVANIZED STEEL Rough-in Box	<p>Hot sudsy water.</p> <ul style="list-style-type: none"> • Wash, rinse thoroughly with hot water, and dry.
ELEMENTS	<p>DO NOT RINSE OR IMMERSE ANY ELEMENT IN WATER. The elements will clean themselves when turned on to the HI setting. Drip pan must be in place. Do not leave the cooktop unattended while cleaning any element.</p>
PLASTIC Control Knobs	<p>Hot sudsy water.</p> <ul style="list-style-type: none"> • Wash, rinse thoroughly with hot water, and dry.
PORCELAIN ENAMEL Cooktop, Griddle'n Grill Cover	<p>Porcelain Enamel used on the cooktop is acid resistant, but not acid proof. If foods such as citric juices, tomatoes, vinegar, milk, etc. are spilled, wipe them up immediately or it may effect the finish.</p> <p>Hot sudsy water.</p> <ul style="list-style-type: none"> • Wash, rinse thoroughly with hot water, and dry. <p>Abrasive Cleaners: Bon ami®, soap filled steel wool pad, S.O.S.</p> <ul style="list-style-type: none"> • For stubborn stains occasional use of mild abrasive cleaners or a soap filled steel wool pad is okay. Abrasive cleaners, used vigorously or too often can eventually harm the enamel.
STAINLESS STEEL Cooktop, Secondary Trays (TMH36), Griddle' Grill Drip Pan Vent (TMHCV36G) <ul style="list-style-type: none"> • Grease, food spatters, fingerprints 	<p>Nonabrasive Cleaners: Hot soapy water, ammonia or detergent and water.</p> <ul style="list-style-type: none"> • Apply with sponge or cloth, then wipe clean using a clean cloth and thoroughly dry the surface. • Wipe off the stainless steel front and back panels of the vent after each use. Rinse, then polish with a dry cloth, rubbing in the direction of the grain. • If grease has accumulated on the inside of the back panel of the vent, use a nylon or other soft-touch spatula to lift the accumulated grease from the back panel. To reach the back panel, remove the front panel and filters. See page 16. <p>Mild Cleaners: General kitchen cleaners such as Fantastic®, Formula 409®. Use a stainless steel polish after cleaning to protect and maintain luster (such as Stainless Steel Magic®).</p> <p>Vinegar: to remove hard water spots.</p> <ul style="list-style-type: none"> • Apply with sponge or cloth, then wipe clean using a clean cloth and thoroughly dry the surface. <p>Mild abrasive Cleaners: RevereWare Stainless Steel Cleaner®, Kleen King® Stainless Steel Cleaner.</p> <ul style="list-style-type: none"> • Apply with a damp sponge or cloth. <i>Rub lightly in direction of the polish lines.</i> Wipe clean using damp cloth or sponge and dry surface. <div style="border: 1px solid black; border-radius: 15px; padding: 10px; margin-top: 10px;"> <p>Remember, chlorine or chlorine compounds (check the labels) are corrosive even to stainless steel. It is very important to rinse thoroughly and dry if a cleaning agent with chlorine is used.</p> </div>
<ul style="list-style-type: none"> • Heat Tint or discoloration 	<p>Abrasive Cleaners: RevereWare stainless Steel Cleaner, Zud®.</p> <ul style="list-style-type: none"> • Apply with a damp cloth or sponge. Satisfactory for uses on all finishes if rubbing is light. <i>Use in direction of polish lines.</i>

COOK'n'VENT™ CARE AND MAINTENANCE

SEE SAFETY PRACTICES ON PAGE 2.

COOK'n'VENT

The efficiency of the exhaust system depends on the cleanliness of the ventilator, especially the filters. The frequency of cleaning depends on the amount and type of cooking performed.

FILTERS and INTAKE PANELS

Filters become soiled in a short period of time and should be cleaned frequently. The filters may be cleaned by agitating them in a hot detergent solution or by washing in the dishwasher.

Do not use the ventilating system without the filters in place.

To Remove the Filters and Clean the Panels

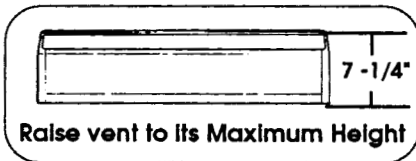

1. As the top of the ventilator rises the cover lifts. Raise the ventilator intake to its maximum height. If the blower is on, turn it off.

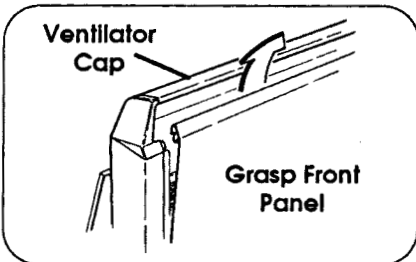

2. Grasp the front panel at the top towards the sides and pull up and forward; remove and set aside.
3. Remove ventilator cap by grasping both ends of the cap and lifting up.

4. Lift out the filters and clean. (See Cleaning Chart, page 14).

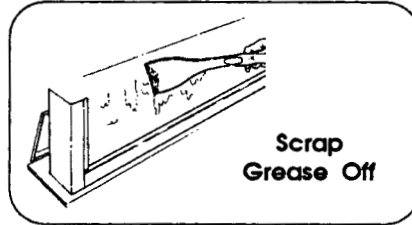

5. Using a nylon or other soft-touch spatula lift the accumulated grease from the back panel - behind the filters. Clean front and back panels using a mild grease solvent (see Cleaning Chart for Stainless Steel, page 14).

♣ TIP: Wipe off the vent intake after each use.

To Replace the Filters and the Front Panel

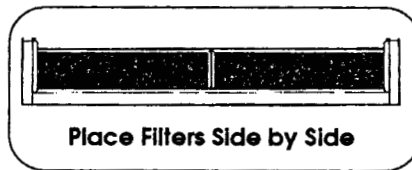

6. Place the filters side by side on the support bars in front of the back panel. They will lean forward and the tops will rest against the inside of the front panel supports.
7. Replace the ventilator cap. Be certain all sides of the cap fit inside the ventilator sides and back panel.

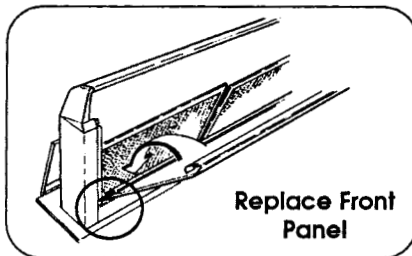

8. Replace the front panel by hooking the lower front edge of the front intake panel over the lower edge of the ventilator.

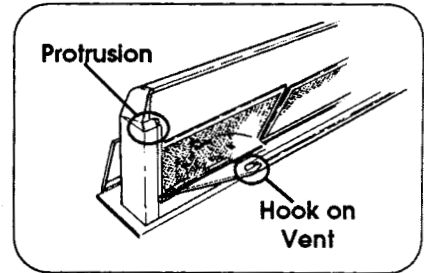

9. Hook the top of the front panel over the side supports at the top of the ventilator.
10. As the ventilator intake is lowered, the cover will flip back into position covering the ventilator.

To Clean Gap Area Between Ventilator and Cooktop

1. With ventilator in up position, remove front panel, ventilator cap and filters.
2. Lower ventilator completely.
3. Clean gap area using a mild grease solvent.
4. Raise ventilator completely and replace filters, cap and front panel.

WARNING

When cleaning the inside of the intake be careful as there are some sharp edges.

COOK'n'VENT CARE AND MAINTANENCE

ACCESS PANELS and ELECTRICAL CONNECTIONS

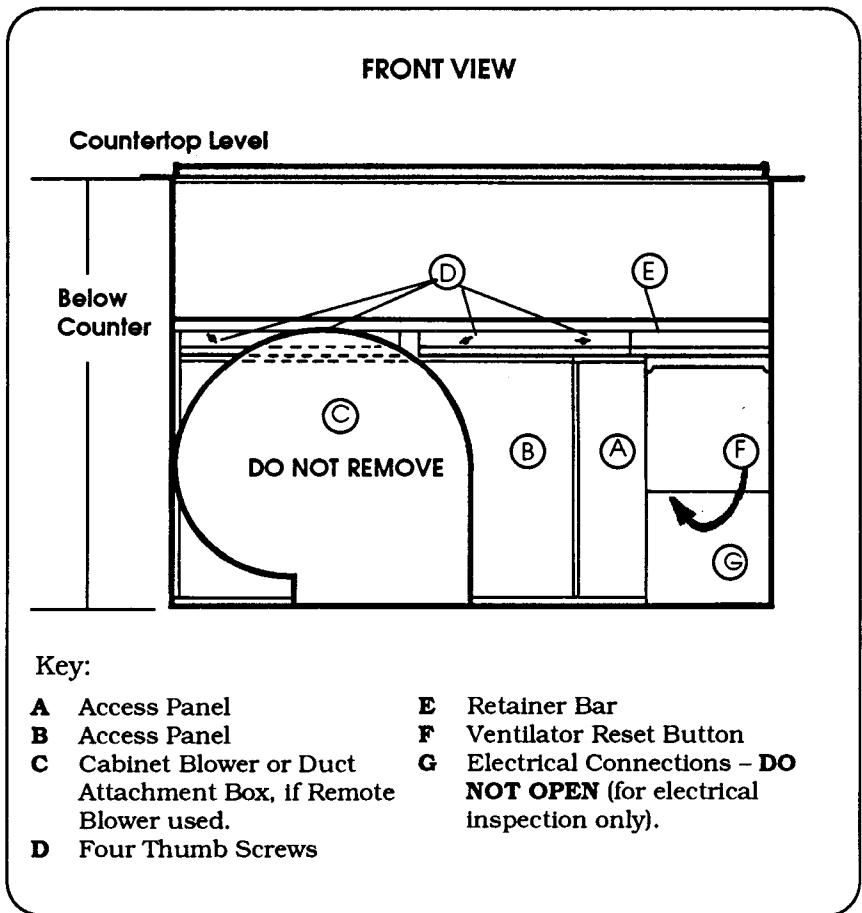
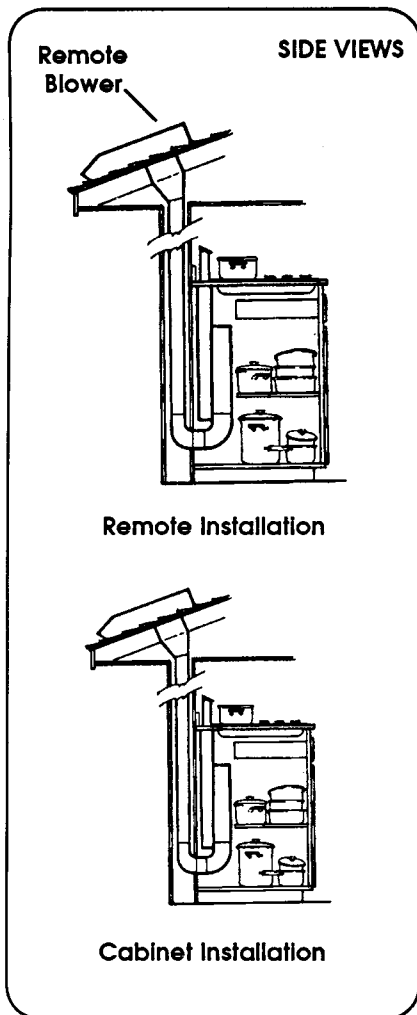

Key:

- | | |
|--|--|
| A Access Panel | E Retainer Bar |
| B Access Panel | F Ventilator Reset Button |
| C Cabinet Blower or Duct Attachment Box, if Remote Blower used. | G Electrical Connections - DO NOT OPEN (for electrical inspection only). |
| D Four Thumb Screws | |

TO REACH CLEAN OUT AREA

1. Loosen (but do not remove) the thumb screws (item **D**).
2. While holding **C** (it is heavy), move the retainer bar **E** up and lift out panels **A** and **B**. Lower the retainer bar **E** so it will hold **C** in place.
3. **Do not** open the electrical box **G** on the right.
4. Wipe up any accumulated grease inside the area. Wipe with a cloth dampened with hot soapy water or use a general household spray for grease. Rinse and dry before closing the compartment.
5. After cleaning, replace the access panels and securely tighten the thumb screws.

DO NOT REMOVE BLOWER C or DUCT ATTACHMENT C (remote blower installation).

You have either a remote or a cabinet blower **C** installed on the ventilation system of your Cook'n' Vent cooktop.

There are access panels at the base of the ventilator system inside the cabinet. If there is a shelf under the cooktop, it must be removable as the Access Panels **A** and **B** and the Electrical Connection Box **G** must be accessible for cleaning, electrical inspection or service. Periodically - **approximately every six months** - check the enclosure behind the access panels **A** and **B** for food soil. Frequency of cleaning depends on how often the filters and back panel at the top of the unit are cleaned.

BEFORE CALLING FOR SERVICE

Before calling for service, check to be sure you do not have one of these problems.

All Models

If the cooktop elements do not heat or if the element "ON" lights do not turn on:

- Check the fuse box to see if a fuse has blown.
- Check the circuit breaker to see if it has tripped.

If one element will not heat:

- Turn all the switches to OFF. Turn off the circuit breaker, then plug in one of the other elements of the same size. If it heats the first element is defective and should be replaced. If it does not heat, call for service.

Models with Griddle'n Grill

If the Griddle 'n Grill element does not heat:

- Check to be certain the element terminals are pushed securely into the receptacle.

If elements need replacement — use **only** original Thermador parts.

Model TMHCV36G

If the ventilation system does not operate:

- Check the reset button located at the bottom of the intake assembly, see Front View page 17, item F.
- The ventilator exhaust assembly and blower are protected by a built-in 15 amp. circuit breaker, see Front View page 17, item F. If the colored band is showing on the reset button, push the button in to restore power. If the reset button will not hold, contact your local authorized service center.

DATA PLATE*

The data plate shows the model and serial numbers for your cooktop.

In models with Griddle'n Grill, the data plate is located under the Griddle 'n Grill drip pan to the rear of the cooktop. Lift out the griddle'n grill drip pan and the data plate will be visible.

On Model TMH30, the data plate is located on the inside of the rough-in box in the center. Remove the 2 front elements and drip pans and lift the top.

On ST Models, the data plate is located on the inside rear of the cooktop rough-in box.

SERVICE INFORMATION

For handy reference, copy the information from the data plate and record below. Keep your purchase invoice/receipt for warranty validation.

*Model Number

*Serial Number

Date of Purchase

Dealer's Name

Dealer's Telephone Number

Service Center Name

Service Center's Telephone Number

Section Seven: Service

WARRANTY — COOKTOPS — TMH, CV2136, ST

FULL ONE YEAR WARRANTY

Covers one year from date of installation, or date of occupancy on a new, or previously unoccupied dwelling. Save your dated receipt or other evidence of installation/ occupancy date.

Thermador Will Pay For:

All repair labor and replacement parts found to be defective due to materials and workmanship.

Service must be provided by a Factory Authorized Service Agency, during normal working hours. For a Service Agency nearest you, please call 800/735-4328.

Thermador Will Not Pay For:

1. Service by an unauthorized agency. Damage or repairs due to service by an unauthorized agency or the use of unauthorized parts.
2. Service visits to:
 - Teach you how to use the appliance.
 - Correct defects or repairs due to improper installation. You are responsible for providing electrical wiring and other connecting facilities.
 - Reset circuit breakers or replace home fuses.
3. Damage caused from accident, alteration, misuse, abuse, improper installation or installation not in accordance with local electrical codes or plumbing codes, or improper storage of the appliance.
4. Service labor during limited warranty period.
5. Travel fees and associated charges incurred when the product is installed in a location with limited or restricted access. (i.e., airplane flights, ferry charges, isolated geographic regions).
6. Repairs due to other than normal home use.

This warranty applies to appliances used in residential applications; it does not cover their use in commercial installations.

The warranty is for products purchased and retained in the 50 states of the U. S. A., the District of Columbia and Canada. Should the appliance be sold by the original purchaser during the warranty period, the new owner continues to be protected until the expiration date of the original purchaser's warranty period. Products for use in Canada must be purchased through the Canadian distribution channel to ensure regulatory compliance and warranty coverage.

This warranty gives you specific legal rights. You may also have other rights which vary from state to state.

HOW TO OBTAIN SERVICE

- Contact the Factory Authorized Service Agent in your area
- Contact the Dealership where you purchased the appliance.
- Call the Thermador Customer Support Call Center at 800-735-4328
- Write us to at: Thermador 5551 McFadden Avenue, Huntington Beach CA, 92649

Thermador is a leading manufacturer of Convection Micro Thermal Ovens, Convection Thermal Ovens, Thermal Electric Ovens, Warming Drawers, Free-Standing and Slide-In Ranges, Steel Gas ExtraLow® Cooktops, Steel Gas Cooktops, Glass Gas ExtraLow Cooktops, Glass Gas Cooktops, Glass Ceramic Gas Cooktops, Glass Ceramic Dual-Fuel Cooktops, Glass Ceramic All-Radiant Cooktops, Glass Ceramic Halogen Cooktops, Electric Cooktops, Professional® All-Gas Ranges and Cooktops, Professional Dual-Fuel Ranges, Cook'n'Vent® Downdraft Ventilation System, Hoods, Ventilators, Housings, Dishwashers and Char-Glo® Outdoor Barbecues. Specifications are for planning purposes only. Refer to installation instructions and consult your countertop supplier prior to making counter opening. Consult with a heating and ventilating engineer for your specific ventilation requirements. For the most detailed information, refer to installation instructions accompanying product or write Thermador indicating the model number.

Thermador reserves the right to change specifications or design without notice. Some models are certified for use in Canada. Thermador is not responsible for products which are transported from the United States for use in Canada. Check with your local Canadian distributor or dealer. Thermador, 5551 McFadden Avenue, Huntington Beach, CA 92649.

For the most up to date critical installation dimensions by fax, use your fax handset and call 702/833-3600. Use code #8030.

Thermador®
C O R P O R A T I O N

5551 McFadden Avenue, Huntington Beach, CA 92649 • 800/735-4328
ECO12080 • 14-41-768D • © Thermador Coporation 1998 • Litho U. S. A. 9/98